

WARRANTY

For one year from the date of purchase to the ORIGINAL owner, if the Mech-Tech Systems CCU is operated and maintained according to the instructions in the owner's manual, Mech-Tech Systems will repair or replace, free of charge, any part found to be defective in material or workmanship. Customers are responsible for freight charges for returning products to the factory. Contact Mech-Tech Systems for return details.

This warranty does not cover: Items which become worn during normal use. Repairs necessary because of operation abuse, negligence, accident, or failure to maintain or operate according to the owner's manual. Unauthorized modifications to the CCU.

Mech-Tech Systems Inc.
3243 US Highway 93 South
Kalispell, MT 59901
www.mechtechsys.com

1-866-433-2122

MECH-TECH SYSTEMS '1911' Model CCU

Operation & Maintenance Manual



- Safety First-

Read and understand this manual before attempting to use this product! If you have any questions call:

1-866-433-2122
(Toll Free!)

www.mechtechsys.com

Made in the USA

Copyright Mech-Tech Systems Inc.
2010 all rights reserved

Mech-Tech CCU Operation & Maintenance

Manual - 1911 Model

1) SAFETY ADDENDUM

This is a safety addendum to follow page 1. Carefull

reading of this manual will reveal that the bolt **must** be

retracted before **any** attempt to remove the pistol lower unit. There can occur a unique circumstance where a cartridge gets stuck in the chamber and the bolt cannot be retracted. The stuck cartridge may not be seated fully into the chamber and this will prevent the firing of the CCU because the bolt is not fully forward. The reason that the bolt cannot be retracted in this case is that the extractor (Fig.5) claw is engaging the case rim. When this situation occurs **do not** try to remove the pistol lower unit because the stuck cartridge may fire as the lower is removed! The correct way to deal with a stuck cartridge case is to carefully lift the extractor claw outward far enough to release its' grip on the cartridge and then move the bolt to the rear and lock it to the rear. This delicate operation is best performed by a competent gunsmith. Care must also be exercised in the subsequent removal of the stuck cartridge

- also a job for a competent gunsmith. Remember there is always the possibility that the stuck cartridge may fire while working to release the extractors' grip. Be certain to position the CCU muzzle such that an unintentional discharge of the cartridge will not pose a hazard to persons or property.

Note to gunsmith: a 6" piece of 14ga (0.033") music wire with a 90 degree x 1/8" bent at one end can be used to pull the extractor nose outward away from the cartridge rim. Also a pair of slender jaw needle nose pliers can do the trick. It is advisable to hold the CCU in a soft jaw vise fixture in the area of the foregrip to allow for both hands to be free to perform the release. An assistant is helpful if the vise is unavailable. Again we stress the importance of safety - be certain to orient the muzzle so that an unintentional discharge will not harm persons or property!

5) Addendum

It is highly recommended that this entire manual is read and understood before operating or disassembling the CCU. If there are questions or any area where you feel clarity is lacking please call the manufacturer for advice at **1-866/433-2122** toll free.

NOTE: the 1911 style pistols have a frame mounted safety lever on the left side. The CCU allows this safety to operate if the lever is the same as a stock Colt original pattern. Extended style safety levers such as are available from aftermarket sources and are found on later manufactured 1911 style pistols **will not function** with the CCU. The last round hold-open feature in 1911's also does not function with the CCU installed. With these exceptions the CCU will function normally.

Remove all ammunition from the CCU when assembling/disassembling pistol lowers to/from the unit. Always point the muzzle in a safe direction. Observe all safety precautions. Use only lowers with factory stock serviceable components. Use only factory ammunition of the caliber for which the CCU has been designed. Wear approved ear and eye protection when firing the unit. Obey local, state and Federal laws at all times.

Wear proper eye protection during disassembly/reassembly. After disassembly clean and lubricate all components before reassembly. Do not modify any CCU components.

Mech-Tech Systems Inc.
3243 US Highway 93 South
Kalispell, MT 59903

Mech-Tech CCU Operation & Maintenance

Manual - 1911 Model

1) Safety

Inherent in virtually all products is the capacity for unsafe use. This applies to everything from automobiles to egg beaters. The Mech-Tech CCU is a piece of mechanical machinery and must be operated with the observation of proper safety procedures.

Read and understand this entire document before attempting operation or maintenance of the CCU.

I) At all times when handling the CCU for routine assembly, disassembly, and/or maintenance procedures be very certain that the CCU and all ammunition are *totally separated* from each other.

II) *Always* open and lock back the bolt before any other handling of the CCU begins.

III) The CCU bolt is a spring loaded assembly. Be careful to observe caution regarding the placement of fingers when the bolt is locked open. Do not place fingers into the ejection port area. Be aware that a potential for pinching fingers or portions of the hand exists also on the cocking handle side of the CCU between the rear of the foregrip and the cocking handle. When the bolt is locked back it has the potential to slam shut if the unit is jarred.

IV) Be certain to *read and understand* the disassembly/assembly instructions before attempting these procedures. The bolt/ barrel subassembly is spring loaded. Always wear appropriate eye protection during these procedures.

V) In the normal operating mode, the CCU is assembled to the lower unit or frame of the pistol for which the CCU is designed and the complete assembly becomes a functioning firearm capable of discharging the same ammunition for which the pistol is designed. This assembly operates in the same semi-automatic mode as the pistol from which the lower unit originated. Observe all of the safety precautions which apply to the pistol as outlined by the pistol manufacturer. Wear appropriate eye and ear protection at all times when firing the CCU.

VI) Use only ammunition of the caliber and style for which the CCU is designed. Use only ammunition loaded by licensed commercial ammunition manufacturers ('factory ammunition'). The use of any other ammunition has the potential to be unsafe and also will

void the warranty applied to the CCU.

VII) For 1911 model CCU's, use only unmodified stock Colt 1911 lowers with all factory approved parts. Mech-Tech requires the same criteria for safety that is required by Colt. Aftermarket parts and other modifications to Colt lowers have shown unsafe operation under certain conditions.

2) Operation

Fig.1 and Fig.2 show a 1911 model CCU completely assembled and indicate the major components and features involved. Fig.4 is a photo of the underside of a CCU housing. Observe in Fig.4 the openings which allow for the assembly of the 1911 lower unit into the CCU housing.

The first step is to install a 1911 frame (lower) unit into the CCU housing. Before attempting this it is helpful to become familiar with the features of the lower unit and the CCU housing which are involved in mating the two components. Refer to Fig.3, a view of the 1911 lower unit, and notice the 'rail' area. This of course is a picture of the lower unit with the slide and barrel removed as would be seen in normal field stripping of the 1911. Next refer to Fig.4 and notice the features indicated in the CCU housing.

There is an opening in the CCU housing into which the 1911 lower unit 'rails' (Fig.3) must be introduced, after which the lower unit is pushed firmly forward (toward the muzzle). ***Before the lower is installed into the CCU be certain to pull the bolt to the rear and lock it there using the bolt handle.*** (Note: observe the shape of the slot on the left side of the CCU housing. An enlarged opening exists about half way to the rear of the slot. When the bolt is pulled fully to the rear, the bolt handle is pushed inward toward the CCU housing and engages the enlarged opening. This locks the bolt in the rear position. To release the bolt pull back on the handle and then pull the handle outward away from the CCU housing and release the handle.) Also be certain to cock the hammer of the lower unit before attempting assembly into the housing. (Be careful to avoid pulling the trigger when the hammer is cocked. Pulling the trigger will of course release the hammer which action can cause damage to the lower unit in the absence of the slide.) Note that the correct orientation of the 1911 lower relative to the housing (Fig.4) is such that the lower unit is pointing toward the

3

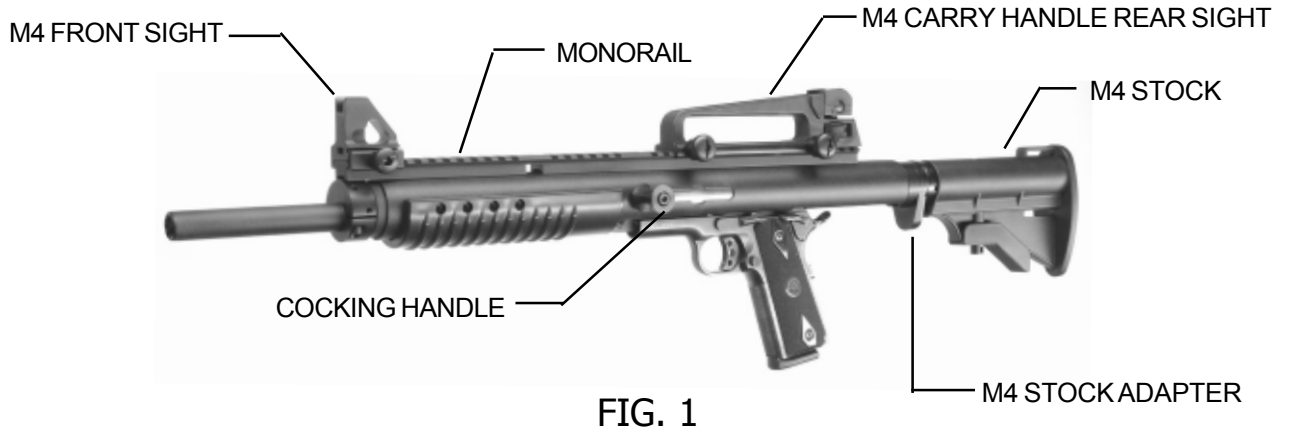

4

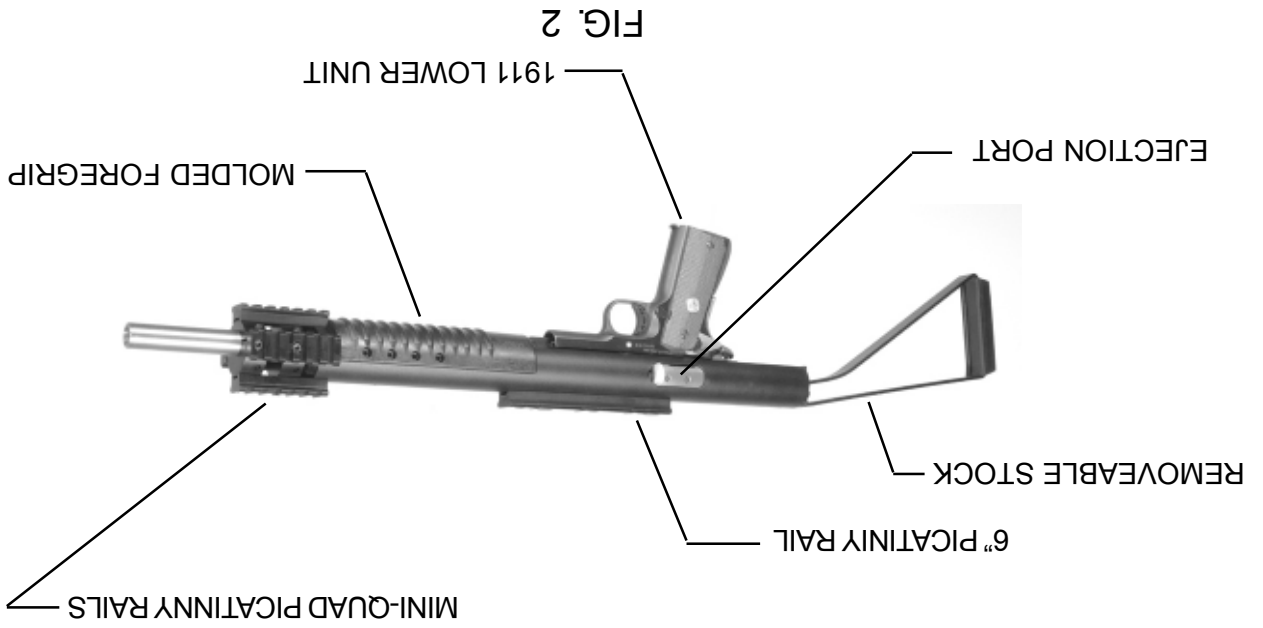

FRAME RAILS

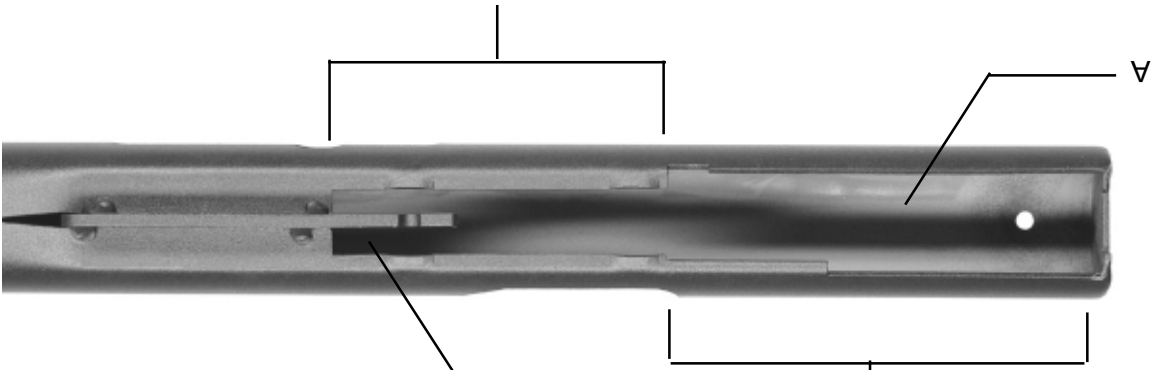

FIG. 3

5

FIG. 4

NARROW PORTION OF SLOT WHICH ENGAGES 1911 FRAME RAIL GROOVES



WIDER PORTION OF SLOT - START BY PLACING FRAME RAILS HERE AND THEN SLIDE FORWARD ENSURING FRAME RAIL GROOVES ENGAGE EDGES OF NARROWER HOUSING SLOT

6

muzzle end of the housing. Be certain that the 1911 lower unit is in full contact with the CCU housing when the 'rails' are in their correct opening and only then push the lower forward. Assembly of the 1911 lower into the housing may be easier with the whole thing upside-down. Be cautious to remember that unintentional release of the CCU bolt during assembly can injure a finger!

A word here may be helpful as to senses of direction as used in this manual. 'Forward' or to the 'front' means toward the muzzle end of the CCU. 'Pointing forward' means in the same direction the bullet flies. The opposite terms also apply to opposite directions. The terms 'up' and 'down' are relative to the normal orientation of the pistol or the CCU as are the terms 'left' and 'right'.

With the 1911 lower unit correctly positioned in the appropriate opening of the housing, the lower may be pushed forward relative to the housing. The housing is designed with 'rails' which engage the 'rails' on the lower unit. Actually it may be best to understand the lower unit as having grooves on the right and left sides into which the housing 'rails' must enter.

Push forward the 1911 lower until it can go no farther. If all is well the slide stop or take-down lever of the 1911 may be installed as it normally would be. This action locks the lower to the CCU housing and the unit is ready to use. When in a position to safely fire the CCU a loaded 1911 magazine may be introduced into the 1911 lower. If the bolt is locked to the rear simply release the bolt rapidly which action will chamber a round and the CCU is ready to fire. If the bolt is closed when a loaded magazine is installed, pull the bolt fully to the rear using the cocking handle and rapidly release it. This will chamber a round making the CCU ready to fire.

There is a safety device designed into the CCU (Fig.9) which prevents the installation of a lower unit into the CCU with the bolt in the closed position. The reason for this device is to prevent an accidental discharge in the event that a live round is in the chamber at the time of assembly. Of course it is possible to defeat about any mechanical device and therefore Mech-Tech stresses that the rules of safety take first place. **Earlier in these instructions is stated the requirement to open and lock back the bolt before any assembly or disassembly activity begins.** Follow the safety rules and there won't be a hole where one is not wanted!

Disassembly of the 1911 lower from the CCU is basically the reverse of the foregoing. Make certain that all ammunition is removed from the CCU.

Remove the magazine from the 1911 lower and lock the bolt in the rearmost position. Locking the bolt to the rear performs two important functions: 1) a round in the chamber will be removed if there is one there; 2) the hammer of the 1911 lower will be cocked which is necessary in order to totally remove the lower.

Remove the slide release (or take-down lever if you prefer) and slide the 1911 lower to the rear until it clears the CCU housing 'rails' and remove it from the CCU housing. Store the CCU with the bolt in the closed position.

A word here is necessary regarding the various possible combinations of 1911 lowers and Mech-Tech CCU uppers. At this writing Mech-Tech manufactures CCUs for all brands of 1911 pistols which accurately conform to Colt 1911 dimensions. All calibers of 1911 lowers will mechanically fit into any 1911 CCU housing. This applies to 'Commander' and 'Officers' size pistols as well as the full-size pistols. All of this means that certain 'cross-caliber' combinations are possible. For example, a .45 ACP lower will function properly with a 10mm CCU upper simply by using the correct magazine in the lower. Also a 10mm or .40 S&W CCU upper will function properly with a 9mm lower simply by using the appropriate magazine in the 9mm lower. This means that one can realize a functioning CCU of a caliber different from that of the parent pistol which is the source of the 'lower' unit. The advantage is probably obvious. A CCU unit firing a 10mm round is significantly more powerful than a 9mm 1911. Again we stress safety - make certain that whatever combination is chosen uses the ammunition and magazine for which the CCU upper is designed.

After correct installation of a lower into the CCU, the combination will function the same as a semi-automatic pistol - one shot per trigger pull. The last round slide lock-back function of the 1911 pistol is not available in the CCU. Safety cannot be overstressed - there is nothing to indicate the condition of the CCU. No readily visible indication is given if the CCU is cocked, loaded and ready to fire. It is the responsibility of the operator to be aware of the condition of the CCU at all times. The next shot is only a trigger pull away! (Tip: when the bolt is closed, a portion of the rear of the cartridge case is visible when the CCU chamber is loaded. Look carefully into the ejection port opening right where the rear of the barrel meets the breech face. Try this with a 'dummy' round or an empty casing to get used to where you should look.

3) Maintenance

The CCU does not 'field strip'. The main areas of concern are lubrication and cleaning. The cleaning of the barrel bore and chamber is performed using the same techniques as with other firearm systems. Use a cleaning rod and a bore brush followed by rod and patch. Use any of the commonly available bore solvents for this. The barrel is stainless steel and does not require any lubrication after cleaning. Lock back the bolt in the open position while cleaning the bore. Be aware that it is possible to inadvertently disengage the lock back and have the bolt slam shut. Keep fingers out of the ejection port area. Clean the breech face using a small scrub brush or an old tooth brush using any of the commonly available gun cleaning solvents.

The inside of the housing in the areas where the bolt slides can be cleaned most effectively using a flush method where these areas are sprayed with one of the commonly available aerosol type gun solvents. Be certain to apply the flush also to the inside of the housing forward of the ejection port. The way to do this is to lock back the bolt and hold the CCU vertically with the muzzle down. Then apply the spray solvent at points 'A' on the housing(see Fig.4). Most of the aerosol type spray solvents come with a small diameter spray 'nozzle' tube which attaches to the container's main nozzle. Insert this tube in about 1/4" at point 'A' and pointing toward the muzzle - then apply a couple of squirts into the housing. After applying the flush solvent, hand cycle the bolt several times while holding the CCU vertically but with the muzzle up. Repeat this process a second time and make certain that the solvent has well drained from the housing before applying a lubricant.

After cleaning the unit, it is necessary to apply a suitable gun lubricant. These lubricants are also available in aerosol spray type containers which are handy but not absolutely necessary. Apply any of commonly available gun lubricants to the following areas with the bolt closed:

- The outside surface of the barrel which is visible from the underside of the CCU. Apply to the right and left sides so as to run down and lubricate the channel in the bolt in which the barrel rides.
- The surface of the bolt visible in the bolt handle slot on the left side of the CCU.
- The inside surfaces of the housing immediately at the rear of the bolt.

- The bolt recoil spring channel also with the CCU pointing somewhat downward. The rear of the spring channel is located at 12 o'clock on the bolt and the spring retaining 'post' can be seen from the rear of the bolt with the bolt closed. Do this immediately after the previous step and then hand cycle the bolt several times with the CCU in a muzzle-down position.

- The rear of the bolt insert at the point where the firing pin protrudes. Hold the unit vertically to allow lubricant to migrate into the firing pin tunnel.

4) Disassembly/Assembly

Before beginning this exercise be certain to wear suitable eye protection because the CCU contains spring loaded subassemblies. There are three major subassemblies in the CCU and these are:

- Barrel subassembly (Fig.7)
- Bolt subassembly (Fig.9)
- Main Housing subassembly (Fig.8)

The first step in disassembly involves removing the first two subassemblies from the inside of the main housing.

Note that the barrel and bolt subassemblies are removed simultaneously and are connected together by the recoil spring (Fig.6). Care must be taken to grasp these two subassemblies as they are withdrawn from the housing so as to insure that they stay together until both hands are available to separate them.

To begin the removal process, remove the bolt handle. You will need a 5/32" hex wrench to remove the bolt handle retaining screw - a #10-32 x 1" SHCS. The bolt handle is a small subassembly which stays with the retaining screw. This subassembly consists of a bolt handle; a bolt handle spring; a bolt handle spring retaining clip; a bolt handle bushing and a 10-32 x 1" socket head cap screw(SHCS). Later CCU units have a re-designed bolt handle system which does away with the spring and spring retaining clip. These use a longer bushing and a 10-32 x 1 1/4" SHCS. The housing for these later units is also re-designed relative to the later bolt handle configuration. The cocking slot for the spring loaded bolt handle has a 'dolls head' relief at the forward limit of the cocking slot. The later rews for the springless bolt handles do not have the 'dolls head' relief. These design variations are minor in nature and will not affect the disassembly procedure at this point. Generally there should be no need to disassemble the spring loaded bolt handle subassembly.

BARREL SUBASSEMBLY

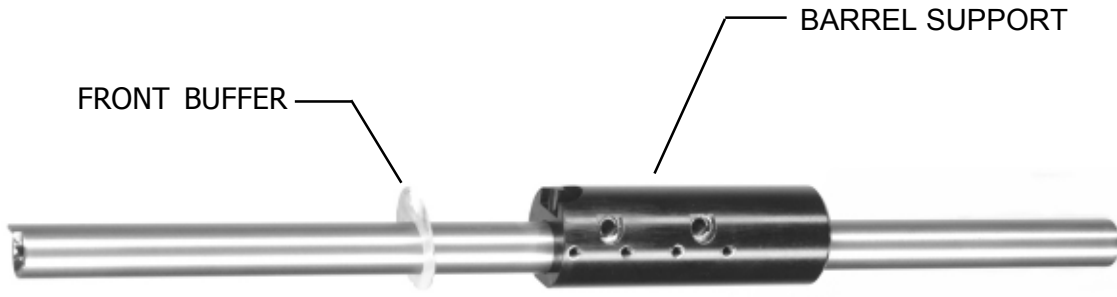
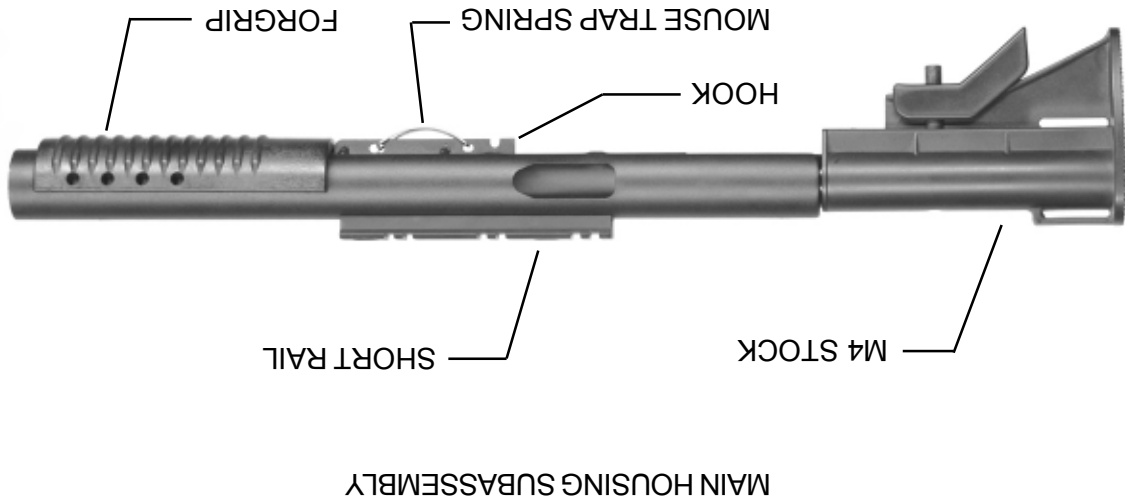

FIG. 7

FIG. 8



BOLT CHANNEL SUBASSEMBLY

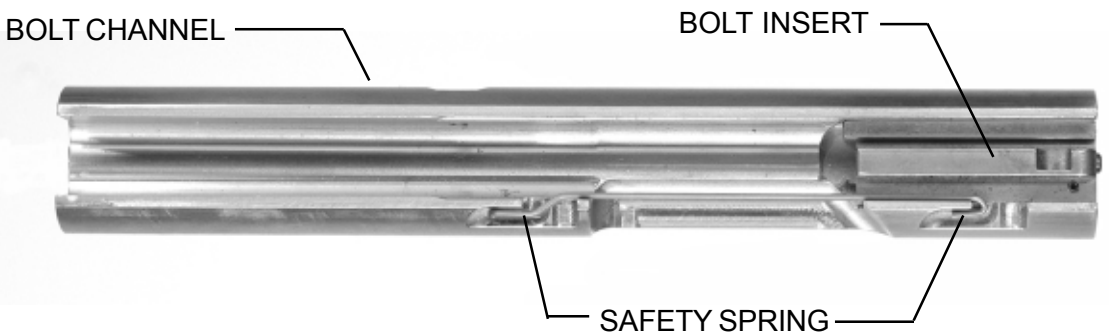

FIG. 9

(Do not use the springless bolt handles with a housing designed for the spring loaded bolt handles and vice versa.)

The next step in the CCU disassembly is to remove a total of 8 SHCS's - 4 on each side of the housing at the front. The heads of these 8 screws also serve to locate the plastic foregrip. You will need a 9/64" hex wrench. The screws are 8-32 SHCS's which are 5/16" long. *Do not* substitute screws of a different length. If one of these screws is lost, you can make one from a longer screw of the same kind, but be very careful to finish with the same thread length as the original.

With the bolt cocking handle and the 8 screws removed, the bolt/barrel subassemblies may be withdrawn from the main housing by pulling forward gently on the barrel. Now things can get tricky. The only thing causing the bolt to follow the barrel forward is the recoil spring. If the CCU has been functioning properly, the bolt moves freely within the housing. If you ran over the CCU with your pickup that will not be the case. If the bolt is stuck it will have to be driven out of the main housing using a short length of wooden dowel, one end pressing against the rear of the bolt while tapping the other end with a mallet.

In this case the bolt will move the barrel out of the housing. Back to the normal way. As the bolt/barrel subassemblies are withdrawn from the main housing, the junction between the bolt and the barrel support will become visible (see FIG.6). Continue the withdrawal until about 3 inches of the bolt is showing. At this point change your grip such that the hand which was pulling on the barrel now grips the two assemblies right over or slightly to the rear of the junction and then continue to withdraw until everything clears the housing. Set down the housing while maintaining a solid grip on the bolt/barrel subassemblies. Don't lose control or the bolt and barrel subassemblies will part company, the recoil spring will suffer damage, and stuff will fly all over the place!

With the housing set down, both hands are free to deal with the bolt/barrel subassemblies. If you are right handed, the bolt/barrel subassemblies will be in your right hand with the barrel pointing to the right. Use your left hand to firmly grip the rear 3 inches of the bolt, trapping the recoil spring under the palm. Work the right hand position slowly toward the muzzle while maintaining the fingers wrapped around the barrel support (FIG.6). Maneuver the right hand such that the right thumb is pressing against the top of the recoil spring retaining post on the barrel support.

Keep the right thumb firmly over the post so as to prevent the recoil spring from leaving the post. Now separate the bolt from the barrel by about 3 inches. Do this by pulling the assemblies apart along an axis parallel to the barrel. You will notice that the recoil spring has stretched. Carefully tilt the barrel, using your right thumb as the approximate pivot point, so that the portion of the barrel which is to the rear of the support moves out of the channel in the bolt. When the barrel just clears the bolt channel, begin to relax the recoil spring by allowing the subassemblies to come together slowly. You will learn how to maneuver the barrel to allow complete relaxation of the recoil spring at which point the spring loop can be safely slipped off the post in the barrel support and you can relax your thumb. (This entire procedure will have to be reversed in order to re-assemble.) The important point of the disassembly is to maintain control over the recoil spring. If the spring should slip off the post and 'snap' closed, the spring will be deformed and should not be used again.

Hopefully one should at this point understand why the directive is given to read and understand this entire manual before attempting disassembly of the unit.

At this point the three basic subassemblies should be separated. To review please refer first to FIG.7 which is the barrel subassembly. Note the front buffer and be certain to have this part in position against the support when re-assembly begins. The barrel and barrel support should not be separated. These parts are assembled using special fixtures and there should be no need to separate them. If the situation arises where the support or barrel are damaged, the subassembly should be sent intact back to the factory for remedy. Refer now to FIG.6 which shows the barrel subassembly and the bolt subassembly held together by the recoil spring. After these have been separated by the techniques outlined above, what is not shown in FIG.7 constitutes the bolt subassembly.

The main housing subassembly should be obvious and consists of the tubular housing with the short sight rail on top and the black plastic foregrip at the front. Also included in this subassembly is the rubber recoil absorber, foregrip and whatever stock happens to be installed (FIG.8) The rubber components are glued in place using a cyanocrylate adhesive. The foregrip simply slides off the housing. Note: your unit may have one of several rail systems installed and of course will differ from the photos.

Upon reassembly, the foregrip is best 'snapped' onto the housing by placing it over the housing, from the underside, in the position where it will be and then pressing it until it snaps over the housing. After this it must be more precisely positioned so that the eight holes in the foregrip align with the eight holes in the housing. It must be perfectly aligned so that the barrel support retaining screws will reassemble properly. Great care must be taken to avoid stripping the threads in the barrel support during reassembly. A word is necessary at this juncture regarding the relationship of the barrel support retaining screws and the main housing. By close examination one can determine that the holes in the housing are larger than the screw heads. This is by design. When properly installed, the screw heads should come up tight against the barrel support and not pinch the housing between the heads and the barrel support. The barrel support is designed to 'float' slightly relative to the housing and the screw heads serve simply as locating pins. All of the dynamic accelerations involved when firing the CCU are absorbed by these screw heads and the housing holes - that is why there are eight of them.

The sight rail on top of the housing may be removed using a nut driver to unscrew the two #8 hex nuts located in recesses on the top surface of the rail. Note that the rail may be assembled in either of two positions. Which position is used is determined simply by preferences of the operator, the optic, and eye relief required. One position places the rail closer to the rear of the unit than the other position. Take your pick. The hex nuts which retain the rail are screwed onto studs which are welded to the housing tube. When reassembling the rail do not overtighten these nuts or the stud threads will be stripped. If the stud threads are stripped, the only remedy is a new housing. It is a good idea to carefully examine the completely assembled CCU before disassembly and to remember how the parts related to each other. If your unit has another rail system installed, follow the instructions for it when removing and re-installing.

The bolt subassembly is the most complicated of the three subassemblies. The components involved are:

- 1) the main bolt channel (FIG.9)
- 2) the bolt insert assembly (FIG. 5)

The bolt insert assembly is retained in the bolt channel by 3 roll pins. These pins must be carefully driven out/replaced with a 3/16" pin punch while properly supporting the bolt in a machine vise.

1911 BOLT INSERT

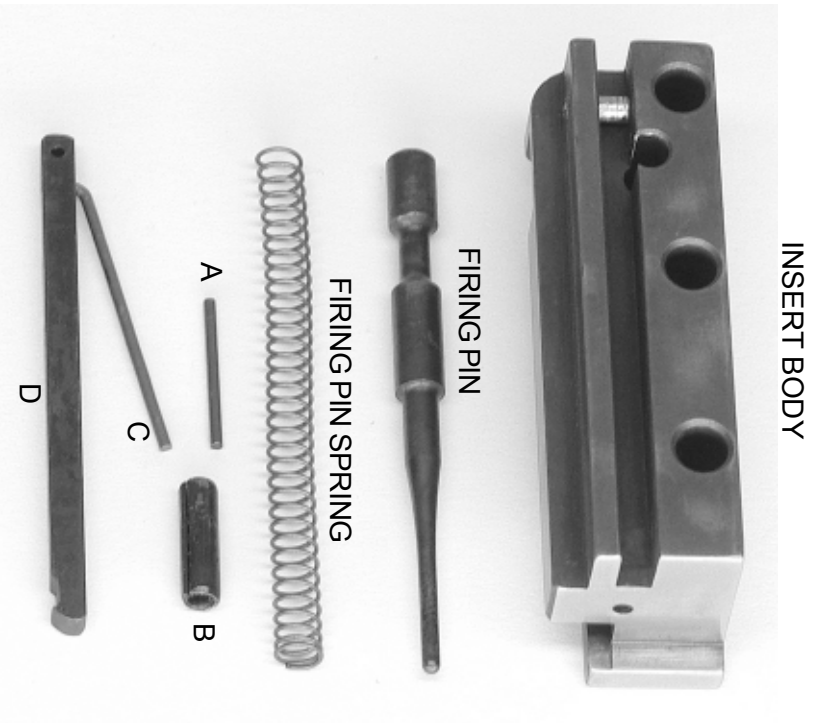

- A - EXTRACTOR PIVOT PIN
- B - FIRING PIN RETAINING PIN
- C - EXTRACTOR SPRING
- D - EXTRACTOR

FIG. 5

FIG. 6

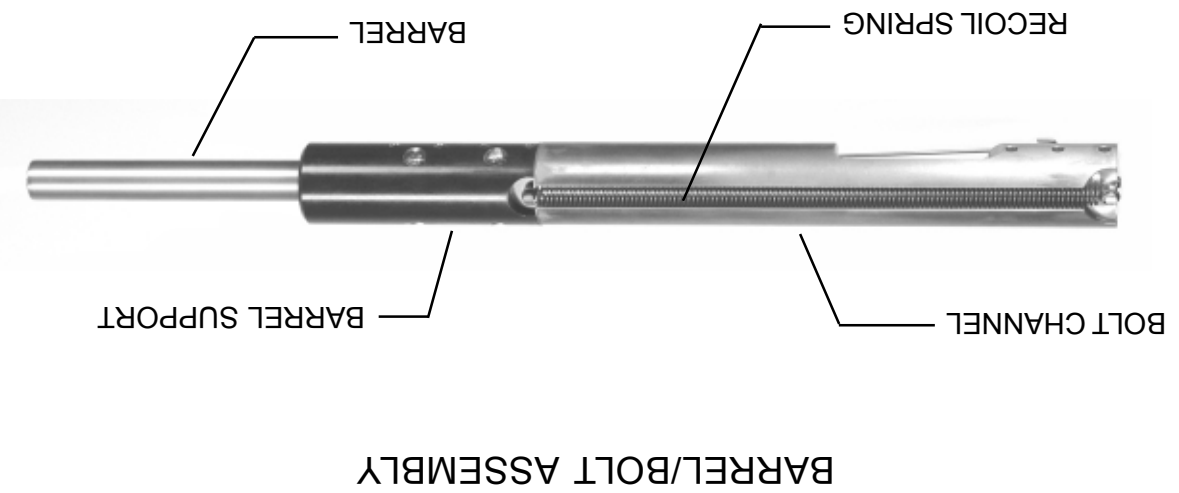

The rotational orientation of the pins is critical. When reassembling the pins it is important that the 'split' in the pins faces forward. (10mm & 460R units have solid pins) After the pins have been driven out, the insert assembly is free to be removed. Note in FIG.5 the various components involved. Take care in removing the insert and note the position of these components. The extractor spring can fall free after the insert has been removed from the channel.

When the extractor pivot pin is removed the extractor falls free. Note carefully how the extractor is oriented. The 'claw' faces inward. The extractor has two small holes at one end. The rear-most hole is larger and it is through this hole that the pivot pin must go when reassembling. The smaller hole just forward of the pivot pin hole is for the extractor spring. The short leg of the extractor spring inserts into this hole while the longer leg points forward and lies parallel to the extractor. When reassembling the insert into the bolt channel be certain to correctly position the extractor spring as described. The spring is caged by the bolt channel. After reassembly, test the extractor function by pulling outward on the claw and note that the claw returns when released. The action of the spring should be evident.

An extremely important component is the safety spring - see FIG.9. This component is precision formed from steel spring wire. It is a deceptively simple part considering the important role it plays in the system. The spring is held in place by an 'L' bend at the front end. The 'L' simply slips into a hole drilled in the bolt channel. As shown in FIG.9 the spring is lying flat in the bolt channel with the hairpin loop at the rear end surrounding a projection machined into the channel. This is NOT the way it is when the channel is removed from the unit - it is shown in FIG.9 lying flat for clarity as to how it relates to the channel when the channel is installed in the main housing. In reality the spring has a set in it such that when the 'L' is in place in its' hole the rear end hairpin loop is raised away from the channel by about 1/2" - totally clearing the projection mentioned above. Make certain to observe this when first disassembling the unit. The spring could actually fall free from the channel when the channel is removed from the housing. Upon reassembly it is important to position the spring with the loop engaging the projection as shown in FIG.9 and hold it in this position while slipping the bolt/barrel assembly (FIG.6) back into the housing. Once the channel is in the housing the spring cannot escape. The function of this spring is discussed in the 'Operation' section of this manual.

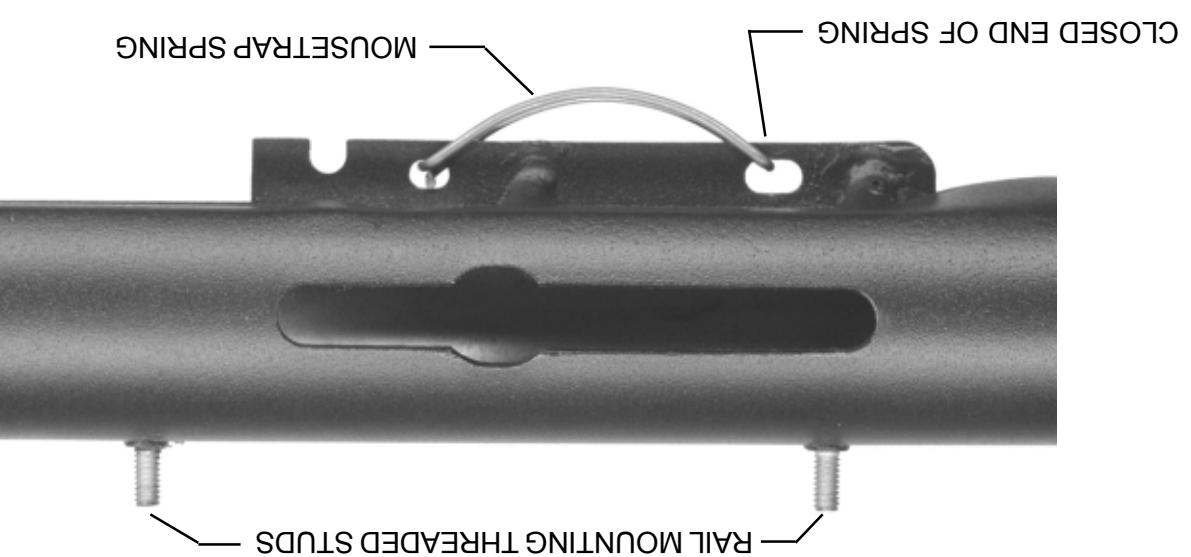

FIG. 10